

# TS Dryer

60HZ



## The TS refrigerated air dryer offers:

### Reliability and Performance

- Consistently delivers dry process air with minimal pressure drop
- 3-in-1 Heat exchanger integrates the pre-cooler and re-heater, heat exchanger and air/water separation to reduce the opportunity for leaks
- High inlet temperatures to 140°F/ 60°C will be accepted with no nuisance shutdowns
- Electrostatic-charged panel filter included on all models for increased package performance

### Productivity

- Refrigeration Expansion valve offers more precise control under varying heat loads from the compressed air and varying ambient temperatures resulting in less risk of product spoilage through dewpoint slippage
- Optimised connection sizes to minimise pressure drop

- Intellisys microprocessor indicates component warnings and if preventative maintenance is needed
- Power Out Restart Operation (PORO) improves productivity

### Energy Efficiency

- “Smart” drain recognises ambient conditions to adjust dwell time and minimise the loss of valuable compressed air
- Energy Saving Efficiency Option to cycle refrigeration compressor is standard

### Health, Safety and the Environment

- Design uses environmentally friendly R404A
- Less refrigerant is needed with MicroChannel condenser design

# TS Dryer

## Refrigerated Air Dryers 60HZ

Model	Flow	CAGI Flow*	Input Power (kW)	PSID	Air In/Out (in)	Weight		Dimensions (in/mm)					
						Lbs	Kg	L		W		H	
TS1A	258	235	2.18	3	1.5 NPT	390	177	33.5	851	26.6	676	55.1	1400
TS2A	343	295	2.56	3.6	2 NPT	456	207	39.0	991	31.5	800	55.1	1400
TS3A	465	415	3.27	3.1	2 NPT	471	214	39.0	991	31.5	800	55.1	1400
TS4A	580	525	3.79	3.3	2 NPT	485	220	39.0	991	31.5	800	55.1	1400
TS5A	687	635	4.22	2.9	2 NPT	880	400	57.4	1458	42.1	1069	61.7	1567
TS6A	972	815	5.9	2.3	2.5 NPT	880	400	57.4	1458	42.1	1069	61.7	1567
TS7A	1070	1040	6.6	4.2	4 Flg	930	423	64.7	1643	42.1	1069	65.7	1669
TS8A	1360	1260	7.56	3.8	4 Flg	950	432	64.7	1643	42.1	1069	65.7	1669
TS9A	1540	1320	9.72	3.3	4 Flg	1340	609	84.6	2091	42.1	1069	65.7	1669
TS10A	1750	1500	10.6	3.3	6 Flg	1350	614	82.4	2091	42.1	1069	65.7	1669
TS11A	2040	1730	13.77	3.2	6 Flg	1350	614	82.4	2091	42.1	1069	65.7	1669
TS12A	2250	1850	14.05	3.3	6 Flg	1350	614	82.4	2091	42.1	1069	65.7	1669
TS13A	2552	1955	16.72	3.1	6 Flg	1400	614	84.6	2091	42.1	1069	65.7	1669

Reference conditions @ 85°F Ambient, 100°F Inlet, 125 PSIG \*Air Capacity @ 100°F Inlet, 100°F Ambient and 100 psig

### Dryer Capacity SCFM

Model	100°F Inlet, 85°F Ambient			140°F Inlet, 115°F Ambient		
	100 PSI	125 PSI	150 PSI	100 PSI	125 PSI	150 PSI
TS1A	250	258	263	95	105	115
TS2A	333	343	350	167	187	207
TS3A	451	465	474	221	248	271
TS4A	563	580	597	278	313	342
TS5A	666	687	700	286	320	347
TS6A	936	972	990	360	405	441
TS7A	1017	1070	1156	385	428	471
TS8A	1322	1360	1385	428	491	529
TS9A	1494	1540	1571	616	693	755
TS10A	1540	1750	1803	735	823	893
TS11A	1980	2040	2100	940	1060	1160
TS12A	2003	2250	2318	945	1080	1170
TS13A	2479	2552	2624	1118	1264	1361

### Operating Limitations

Maximum Pressure	150 Psig
Maximum Inlet Temp	140°F
Maximum Ambient	115°F

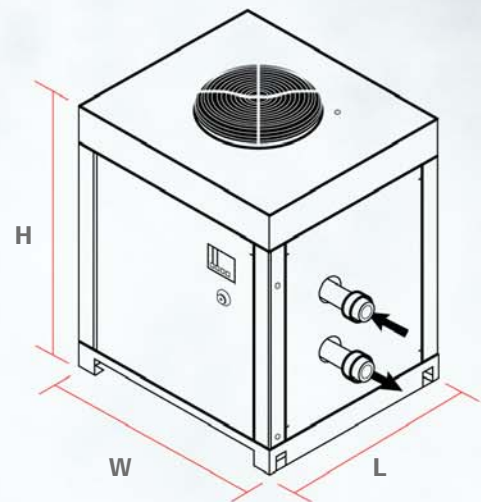

**Ingersoll Rand Company**  
Air Solutions  
P.O. Box 1840  
800-D Beatty Street  
Davidson, NC 28036

Ingersoll Rand compressors are not designed, intended or approved for breathing air applications. Ingersoll Rand does not approve specialised equipment for breathing air applications and assumes no responsibility or liability for compressors used for breathing air service. Nothing contained on these pages is intended to extend any warranty or representation, expressed or implied, regarding the product described herein. Any such warranties or other terms and conditions of sale of products shall be in accordance with Ingersoll Rand's standard terms and conditions of sale for such products, which are available upon request.

Product improvement is a continuing goal at Ingersoll Rand. Designs and specifications are subject to change without notice or obligation.