

Ingersoll-Rand®

Single Stage Air Compressors, Electric Drive

Ingersoll-Rand, the world's leader in air compressor manufacturing, is proud to bring industrial quality to the commercial and contractor trades!

Designed for the professional, our 3-5HP single stage air compressors are ideal for most anyone, from the do-it-yourselfer to the professional air compressor user. When performance is defined by maximum operating pressure, increased air flow, and extended duty cycles, Ingersoll-Rand is the product of choice.

Powerful...

- Maximum Air Power!
More delivered air (cfm) providing the power to do the job right and in less time.
- 100% continuous duty for the toughest applications
- Higher pressure. 135 psig maximum operating pressure

Durable...

- Built to Last!
Durable cast iron construction
- Extended Pump Life! 5,000+ hours for years of trouble-free service
- Industrial quality design

Reliable...

- Precision engineered quality components
- Simple, efficient, easy to maintain finger valves
- Extended two year warranty offered with the use of Ingersoll-Rand's All Season Select synthetic lubricant



LEGENDARY PERFORMANCE



Technical Specification Guide

Standard Features Oil-lube, Single Stage, Electric Drive

- Quiet operation
- Durable 100% cast iron cylinders and frame.
- 100% continuous duty cycle
- Manual thermal overload protection of the motor. No starter required.
- Automatic start/stop pressure switch control with manual on/off lever.
- 60 gallon vertical ASME receiver tank including discharge mounted check valve, pressure gauge, drain valve, service valve and relief valves.
- Totally enclosed beltguard provides a shield around the flywheel, belt and motor sheave.
- Fully assembled
- All units are prewired and thoroughly tested prior to shipment.
- Splash Lubrication
- 230-1-60 Voltage
- Meets OSHA standards
- UL/CSA/ASME compliant

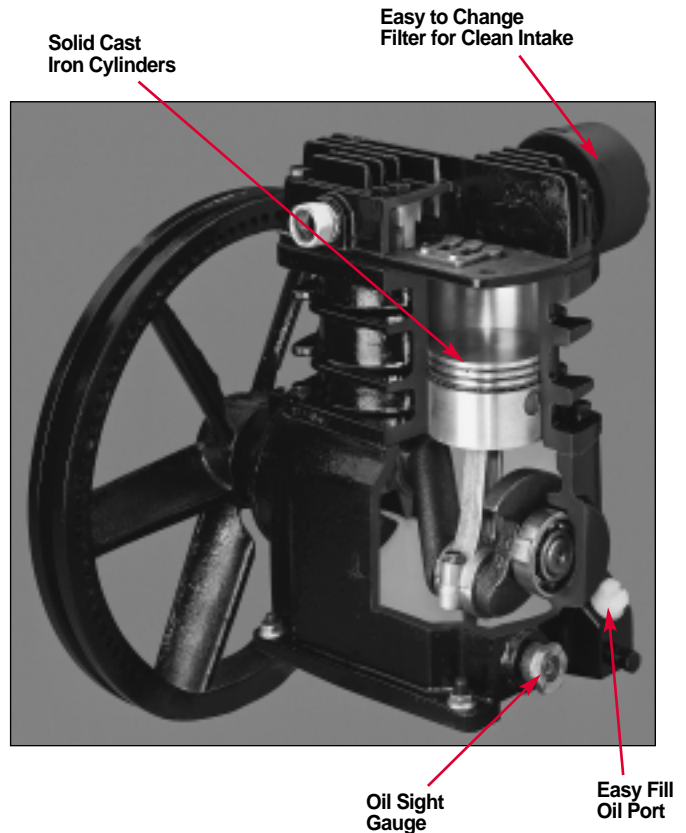

Specifications

Model	Running HP	Tank Size	Voltage	Capacity (cfm) @90psi/135psi	Maximum Pressure	Package Dimensions L/W/H (in.)	Net Weight (lbs.)
SS3L3*	3	60 gallon vertical	230/1/60	11.3 / 10.3	135	20 x 23 x 66	300
SS5L5**	5	60 gallon vertical	230/1/60	18.1 / 15.5	135	20 x 30 x 71	310

*3 HP Running, 7.9 Peak HP

**5 HP Running, 11.8 Peak HP



MORE THAN AIR. SOLUTIONS.

Online solutions: www.irco.com



Ingersoll-Rand compressors are not designed, intended or approved for breathing air applications. Ingersoll-Rand does not approve specialized equipment for breathing air applications and assumes no responsibility or liability for compressors used for breathing air service.

Nothing contained on these pages is intended to extend any warranty or representation, expressed or implied, regarding the product described herein. Any such warranties or other terms and conditions of sale of products shall be in accordance with Ingersoll-Rand's standard terms and conditions of sale for such products, which are available upon request.



Ingersoll-Rand Company

Air Solutions - Commercial and Retail
800-D Beaty Street
Davidson, NC 28036